

Soldier Health Care Monitoring & Tracking System Using IOT

G.Harinee¹, R.Ramya²

1(Department Of Ece/M.A.M College)

2(Assistant Professor Ece/M.A.M College)

Abstract: Embedded is a combination of software and hardware, when a technology is used to do a particular task it is called embedded system. Embedded system is widely used automobiles, industrial automation, home appliances, mobile and aeronautics. Embedded technology uses PC or a controller to do the specified task and the programming is done using assembly language programming or embedded C. Wireless Sensor Network technologies have become a latest research area in health care industries due to rapid maturity in improving the quality of life of a patient. Wireless Sensor Networks when work in medical field provide continuous monitoring of vital health parameters which over a long period of time provide doctors much needed help to make accurate diagnosis and giving better treatment using Internet of things.

Keywords: Gps, Heat Sensor, Iot, Micro Controller, Relay.

I. Introduction

The infantry soldier of tomorrow promises to be one of the most technologically advanced modern warfare has ever seen. Around the world, various research programs are currently being conducted, such as the United States' Future Force Warrior (FFW) and the United Kingdom's Future Infantry Soldier Technology (FIST), with the aim of creating fully integrated combat systems. Alongside vast improvements in protective and weaponry subsystems, another major aspect of this technology will be the ability to provide information superiority at the operational edge of military networks by equipping the dismounted soldier with advanced visual, voice, and data communications. Helmet mounted visors, capable of displaying maps and real-time video from other squad members, ranges of physiological sensors monitoring heart rate, core body temperature etc. These devices will improve situational awareness, not only for the host, but also for collocated military personnel who will exchange information using wireless networks.

The challenge was to integrate these piecemeal components into a lightweight package that could achieve the desired result without being too bulky and cumbersome or requiring too much power. One of the fundamental challenges in military operations lies that the soldiers are not able to communicate with control room station. In addition, the proper navigation between soldier's organizations plays important role for careful planning and co-ordination. So in this paper we focus on tracking the location of soldier from GPS, which is useful for control room station to know the exact location of soldier and accordingly they will guide them. Also Highspeed, short-range, soldier-to-soldier wireless communications to relay information on situational awareness. GPS navigation, Bio-medical sensors, Wireless communication.

II. Proposed System

It consists of two unit's viz., "Soldier unit" and "Server unit". The wireless technology (IoT) is used in our project for the communication. We are using a ARM programmable IC (LPC 2148). GPS is interfaced with the Soldier Unit (moving unit) which sends the current location of the soldier in the battle field, to the server unit, via IoT module. The receiver in the server unit receives the signal and tracks the location. Heart beat sensor and temperature sensor are attached with the soldier unit, to check if the soldier is alive or dead, and sends the information to the server unit. In any emergency situation soldier can contact the server by giving a request through keypad interfaced with the unit. To prevent inactive the body part for examples finger, heart, leg& hand due to heavy snow. Thermoelectric cooling uses the peltier effect to create a heat flux between the junctions of two different types of materials which is wearied by soldier for worm up. LCD display shows the status. The server unit monitors via Cloud (PC or Mobile phone). LCD display shows the status.

III. Block Diagram

3.1. Soldier Unit

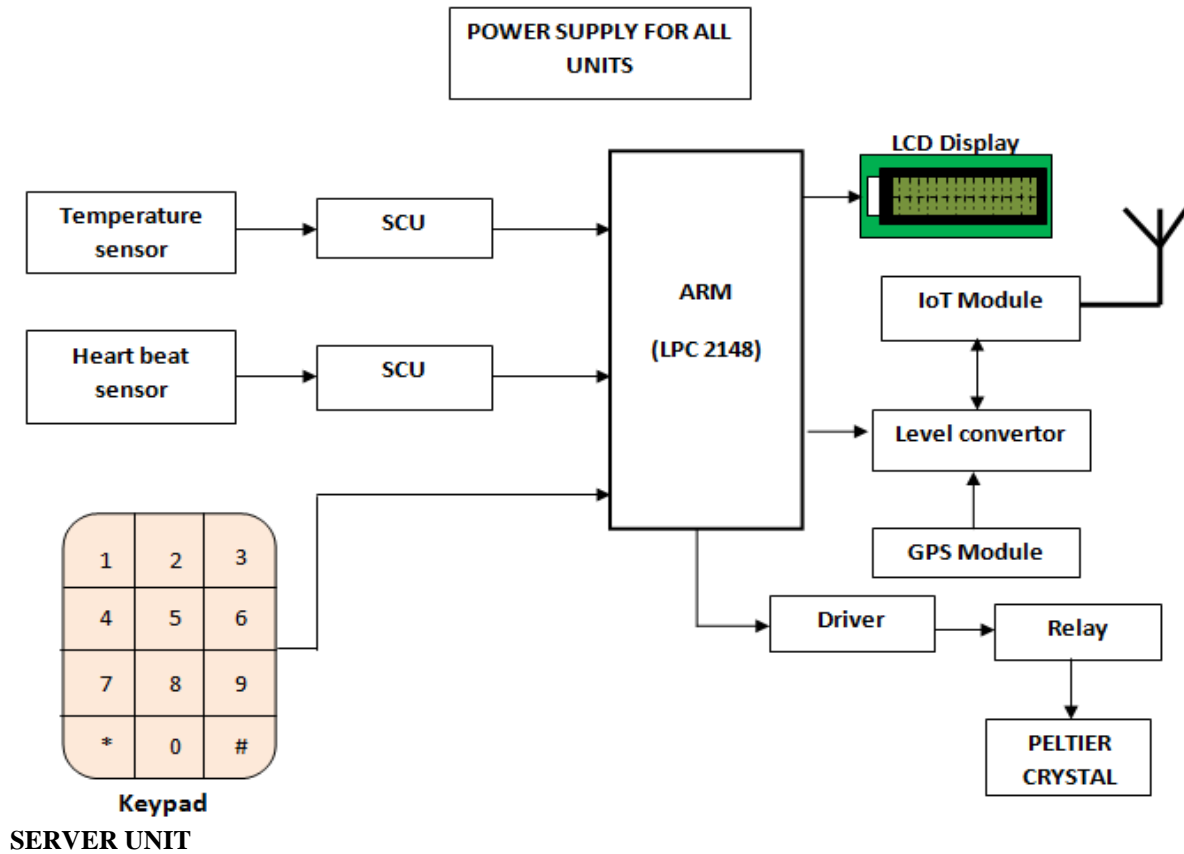

SERVER UNIT

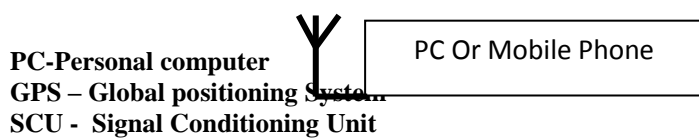

Fig. 1. block diagram of the soldier and server unit

IV. Components Description

4.1. BATTERY CELLS

Battery Cells are the most basic individual component of a battery. They consist of a container in which the electrolyte and the lead plates can interact. Each lead-acid cell fluctuates in voltage from about 2.12 Volts when full to about 1.75 volts when empty. Note the small voltage difference between a full and an empty cell (another advantage of lead-acid batteries over rival chemistries).

Lead acid battery

A lead-acid battery is an electrical storage device that uses a reversible chemical reaction to store energy. It uses a combination of lead plates or grids and an electrolyte consisting of a diluted sulphuric acid to convert electrical energy into potential chemical energy and back again. The electrolyte of lead-acid batteries is hazardous to your health and may produce burns and other permanent damage if you come into contact with it.

4.2. HEART BEAT SENSOR:

Heart beat sensor is designed to give digital output of heart beat when a finger is placed on it. When the heart beat detector is working, the beat LED flashes in unison with each heart beat in fig.2. This digital output can be connected to microcontroller directly to measure the Beats Per Minute (BPM) rate. It works on the principle of light modulation by blood flow through finger at each pulse.

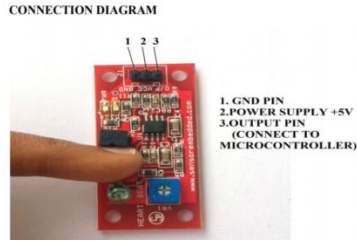

Fig.2.Heart Beat Sensor

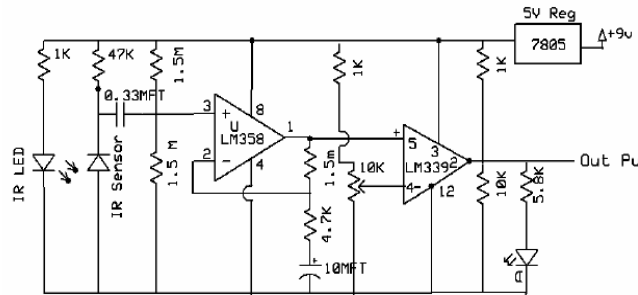

Fig.3.Circuit Diagram Of Heart Beat Sensor

This is a non-invasive measurement for changes in finger blood flow during wakefulness and sleep. Pulse wave amplitude (PWA) is the most frequently used parameter obtained by finger plethysmography. fig.3. PWA is directly and positively correlated to finger blood flow. The hypothesis of this study was that finger plethysmography detects pharmacologically induced changes in finger blood flow.

4.3. TEMPERATURE SENSOR (LM35):

The LM35 is an integrated circuit sensor that can be used to measure temperature with an electrical output proportional to the temperature (in °C) in fig.4 and fig.5. The LM35 generates a higher output voltage than thermocouples and may not require that the output voltage be amplified.

PIN DIAGRAM:

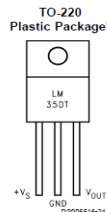

Fig.4.Temperature Sensor

CIRCUIT DIAGRAM

TEMPERATURE SENSOR

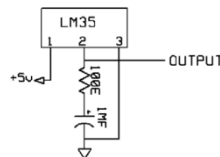

Fig.5.Circuit Of Temperature Sensor

4.4. MATRIX KEYPAD

Keypads are a part of HMI or Human Machine Interface and play really important role in a small embedded system where human interaction or human input is needed in fig.6. Matrix keypads are well known for their simple architecture and ease of interfacing with any microcontroller.

